

Genetic Study of Hepatocyte Nuclear Factor 1 Alpha Variants in Development of Early-Onset Diabetes Type 2 and Maturity-Onset Diabetes of the Young 3 in Iran

Abstract

Background: Maturity-onset diabetes of the young (MODY) is a clinically and genetically heterogeneous group of diabetes characterized by noninsulin-dependent, autosomal-dominant disorder with strong familial history, early age of onset, and pancreatic beta-cell dysfunction. Mutations in at least 14 different genes are responsible for various MODY subtypes. Heterozygous mutations in the hepatocyte nuclear factor 1 alpha (*HNFI1A*) gene are responsible for the MODY3 subtype, which is a common subtype of MODY in different studied populations. To date, more than 450 different variants of this gene have been reported as disease causing for MODY3. This study was carried out to evaluate *HNFI1A* mutations in Iranian diabetic families fulfilling MODY criteria. **Materials and Methods:** Polymerase chain reaction and Sanger sequencing were performed. All the ten exons of the *HNFI1A* gene were sequenced in ten families, followed by cosegregation analysis and *in silico* evaluation. Computational protein modeling was accomplished for the identified mutation. **Results:** MODY3 was confirmed in two large families by detecting a mutation (p.G253E) in coding regions of *HNFI1A*. Compound heterozygous state for two common variants in *HNFI1A* (p.I27 L and p.S487N) was detected in affected members of 5 families, and in one family, a rare benign variant in the coding sequence for Kozak sequence was detected. Two new nonpathogenic variants were found in noncoding regions of *HNFI1A*. **Conclusion:** It seems that *HNFI1A* mutations are a common cause of MODY in Iranian diabetic patients. Identified common variants in heterozygous state can cause diabetes Type II in earlier ages. The role of rare variant rs3455720 is unknown, and more investigation is needed to uncover the function of this variant.

Keywords: Gene, hepatocyte nuclear factor 1 alpha, Iran, maturity-onset diabetes of the young 3, mutation

Introduction

Maturity-onset diabetes of the young (MODY) is a clinically and genetically heterogeneous group of diabetes characterized by noninsulin-dependent, autosomal-dominant disorders with strong familial history, early age of onset, and pancreatic beta-cell dysfunction.^[1] MODY is the most common type of monogenic diabetes and accounts for 1%–2% of all diabetes.^[2] Disease onset occurs usually under the age of 25, and strong family history is observable in the pedigrees. Heterozygous mutations in at least 14 different genes can cause 14 different MODY subtypes.^[3,4] The frequent misdiagnosis of MODY cases with common types of diabetes often leads to improper treatment of the disease and unfavorable

outcomes.^[5] Therefore, molecular diagnosis of MODY is necessary to distinguish it from other types of diabetes and to diagnose the related MODY subtypes which would help in providing the best management of the disease.^[6,7] In MODY patients, insulin is produced by beta-cells, but failure in insulin secretion leads to hyperglycemia. Although at the final stages of some subtypes of MODY insulin,

Address for correspondence:

Dr. Mohammad Amin Tabatabaiefar,
Department of Genetics and Molecular Biology,
School of Medicine and Pediatric Inherited Diseases
Research Center, Research Institute for Primordial
Prevention of Non-Communicable Disease, Isfahan
University of Medical Sciences,
Isfahan 81746-73461, Iran.
E-mail: tabatabaiefar@med.mui.ac.ir

How to cite this article: Mohammadi A, Eskandari A, Sarmadi A, Rahimi M, Iraj B, Hashemipour M, *et al*. Genetic study of hepatocyte nuclear factor 1 alpha variants in development of early-onset diabetes type 2 and maturity-onset diabetes of the young 3 in Iran. *Adv Biomed Res* 2019;8:55.

Received: February, 2019. **Accepted:** July, 2019.

Aliasgar Mohammadi¹,
Ameneh Eskandari¹,
Akram Sarmadi²,
Mehrali Rahimi³,
Bijan Iraj⁴,
Mahin Hashemipour^{5,6,7},
Morteza Hashmezadeh Chaleshtori²,
Mohammad Amin Tabatabaiefar^{1,7}

From the ¹Department of Genetics and Molecular Biology, School of Medicine, Isfahan University of Medical Sciences, ⁴Isfahan Endocrine and Metabolism Research Center, Isfahan University of Medical Sciences, ⁵Department of Endocrinology, Isfahan University of Medical Sciences, ⁶Department of Pediatrics, Faculty of Medicine, Imam Hossein Hospital, Isfahan University of Medical Sciences, ⁷Pediatric Inherited Diseases Research Center, Research Institute for Primordial Prevention of Noncommunicable Disease, Isfahan University of Medical Sciences, Isfahan, ²Cellular And Molecular Research Center; Institute of Basic Health Sciences, Shahrekord University of Medical Sciences, Shahrekord, ³Department of Endocrinology, School of Medicine, Kermanshah University of Medical Sciences, Kermanshah, Iran

Access this article online

Website: www.advbiores.net

DOI: 10.4103/abr.abr_54_19

Quick Response Code:



This is an open access journal, and articles are distributed under the terms of the Creative Commons Attribution-NonCommercial-ShareAlike 4.0 License, which allows others to remix, tweak, and build upon the work non-commercially, as long as appropriate credit is given and the new creations are licensed under the identical terms.

For reprints contact: reprints@medknow.com

consuming is inevitable for some patients, some subtypes such as MODY3 and MODY1 are highly sensitive to oral sulfonylureas tablets.^[8,9] Mutations in *HNF4A* (MODY1), *GCK* (MODY2), hepatocyte nuclear factor 1 alpha (*HNF1A*) (MODY3), and *HNF1B* (MODY5) genes have been reported as the most common causes of MODY. *HNF1A* mutations are the most common causes of MODY in many different studied populations.^[9]

HNF1A or *TCF1* (MIM; 142410) on human chromosome 12 (12q24.31), containing 10 exons, is expressed predominantly in the liver and kidney and encodes a peptide containing 631 aminoacids, known as HNF1A.^[1] Three functional domains have been identified in HNF1A protein: dimerization domain, DNA-binding domain (DBD), and transactivation domain. HNF1A interacts with other Transcription Factors such as HNF1B and HNF4A via dimerization domains to regulate the related genes expression.^[10] For the first time, Yamagata *et al.* reported mutations in the *HNF1A* gene in MODY patients.^[11] To date, more than 450 various mutations including missense, frameshift, insertions/deletions, and complete or partial deletion of exons have been reported in the *HNF1A* gene.^[12] Heterozygous mutations of *HNF1A* lead to MODY3 (MIM; 600496). Without suitable medical interventions, it can lead to macro- or micro-vascular heart, kidney, and eye complications.^[13,14] Usually, age of MODY onset is under 25; therefore, the course of the disease is longer than type 2 diabetes. Untreated MODY3 patients finally will experience awesome consequences of diabetes, even ketoacidic attacks.^[15] The frequency of MODY3 and *HNF1A*-related mutations are not estimated in Iran. In the present research, based on MODY criteria, the authors evaluated the prevalence of *HNF1A* mutations among Isfahan province diabetic patients.

Materials and Methods

Subjects

In the present research, 6500 patient files of diabetic patients (from Sedighe Tahereh Endocrine and Metabolism Research Center, Isfahan, Iran and Dr. Mahin Hashemipour Endocrinology Clinic, Isfahan, Iran) were checked to find MODY patients. 250 patients were selected for genetic counseling. After taking informed consent, sampling was done for selected individuals. Based on MODY criteria, 50 patients were examined for clinical and laboratory features of MODY (hyperglycemia, age of onset under 30, strong history of diabetes [at least observed in three generations], detectable values of C-peptide ≥ 10 ng/ml, negativity for gamma glutamic acid decarboxylase (GAD 65) autoantibodies, responsiveness to sulfonylureas drugs [gliclazide and glibenclamide], and no history for ketoacidosis attacks, regardless to diagnosis as type 1 or type 2 of diabetes). Finally, 10 patients fulfilling MODY criteria were selected for genetic testing of *HNF1A*. Familial history of each patient was obtained,

and pedigrees were drawn by a geneticist. After taking informed consent, blood sampling was done for affected and normal available members of the families. Blood samples were obtained from each individual; samples were kept in ethylenediaminetetraacetic acid containing vials.

DNA extraction and Sanger sequencing

Genomic DNA extraction from peripheral blood lymphocytes was carried out using Prime Prep Genomic DNA Extraction kit from blood (GeNet Bio, Korea). Qualitative and quantitative control of genomic DNA was performed by 1.2% agarose gel and Nanospec cube biophotometer (Nanolytik®, Dusseldorf, Germany), respectively. Primers for all 10 exons of the *HNF1A* gene were designed using primer3 v. 0.4.0 (<http://bioinfo.ut.ee/primer3-0.4.0/>) online web-based software, encompassing at least 60 base pair nucleotides flanking exons, and they were checked by the NCBI primer blast for affinity and specificity. Primer sequences are presented in Table 1. Under standard conditions, polymerase chain reaction (PCR) was applied in all the exons amplification (V: 2 μ l Genomic DNA, 2X Master Mix [Ampliqon®, Denmark]). An automated Genetic Analyzer ABI 3130XL (Applied Biosystems, Foster City, California, USA) was recruited for bidirectional sequencing of PCR products using Big Dye Terminator Cycle Sequencing Kit (Applied Biosystems, Foster City, California, USA). For coding variant calling, sequences were compared to reference sequences NM_000545 and NP_000536.5. *In silico* analysis was performed using MutationTaster2.0, SIFT, PolyPhen-2, PON-P2, PROVEAN, PANTHER, and FATHMM. According to the ACMG guidelines, variant interpretation was done, and variant nomenclature was based on HGVD rules.

Results

Clinical findings

The first proband carrying mutation was a 35-year-old woman diagnosed with gestational diabetes at age 23, with elevated levels of oral glucose tolerance test (OGTT) and glycosuria. She received insulin during the gestational period. After delivery, treatment with insulin was stopped, and metformin was prescribed but no proper blood glucose level control was achieved even with high doses of metformin. Elevated levels of HbA1c showed that metformin could not be the drug of choice for her. Serum was negative for Anti-GAD 65 autoantibodies, and C-Peptide levels were detectable, and there was no evidence of insulin resistance. Body mass index (BMI) was 23.2 kg/m². Her 70-year-old mother had been diagnosed with diabetes Type II at age 32 and she had received oral hypoglycemic drugs such as metformin and glibenclamide for many years; but now, the mother's blood sugar levels are controllable by administration of a low to moderate doses of insulin. After confirmation of MODY for the

Table 1: Primer sequences for amplification of the exons of hepatocyte nuclear factor 1 alpha

Exon	Forward primer (5''3')	Reverse primer (5''3')	PCR product length (bp)	Annealing temp (°C)
1	TGCAAGGAGTTTGGTTTGTG	GAAGGTCATGGGGACTCAAC	536	58
2	CCTCAGGGTTGACAAGGTTT	TGTGTAATGGGGATGGTGAA	395	57
3	GCCATGGCAATGAGAAAAGAA	GGCAACTGGACAGCCTTTTA	387	55
4	GGCAGAGCTCAGCTTCTCAG	AAGGAGTGGCATGAATGGAA	464	55
5	GCCTAAGCAAACCAATGGAG	CAGCTGCTGAGACCTACGAG	391	58
6	CCAACCTCATCTTTCCTTGG	AATGAATGAATGAGTCCCAGTG	400	61
7	CTCTGGGAAGGAGAGGTGGT	GTCCAGAGACACATGCAGA	397	63
8	TTTTGAAAATCAGCCCTGGA	CTGGAGGCCTCAGTGTCTG	389	59
9	ACCAAGCAGGTAAGGTCCAG	CTTCCTCACAGCAGCCCTA	375	61
10	TGAGTACCCTAGGGACAGG	CCTGCCTTCCCTGTTAGCTT	640	62

PCR: Polymerase chain reaction

proband, metformin was changed to glibenclamide (a sulfonylureas), and proper glyceimic control was achieved. Family history chasing showed the history of diabetes in three generations, and multiple affected members were found, indicative of autosomal dominant (vertical) transmission mode of inheritance [Figure 1].

In the second case, the proband was a 12-year-old girl. Having a positive family history of diabetes in the paternal family, she was referred to an endocrine specialist. She experienced mild progressive hyperglycemia since age 10. Fasting blood sugar levels such as OGTT were increased slightly. Serum was negative for anti-GAD 65 autoantibodies, and measurable amounts of C-peptide were detected. Her BMI was normal (24.7 kg/m²), and glycosuria was absent. There was no history of insulin resistance in the family. She was responsive to low doses of metformin. Her affected father had experienced diabetes, and subsequently, hypoglycemia caused by gliclazide (sulfonylureas) was prescribed at age 20. The pedigree information showed autosomal dominant inheritance of diabetes in the family, and multiple affected members were observed in the family pedigree [Figure 2].

In the remained families in this research, the mean age of diabetes onset was between 5 and 25 years, BMI was between 22 and 26, history of diabetes was positive in only one parental family, and there was no history of diabetic ketoacidosis attacks.

DNA sequencing results

Sanger sequencing results revealed the missense mutation g.1566G>A (c.758G>A; p.G253E) [Figure 3] in two unrelated probands, both of whom were heterozygous for the mutation. Cosegregation analysis was performed for both families and revealed the same mutation in affected members, and no mutation was detected in the normal members of both families.

In five families, compound heterozygosis state was disclosed for two common variants (p.I27L and p.S487N) [Figure 4]. In one of the families, a rare variant rs561269721 [Figure 5] was detected in affected members.

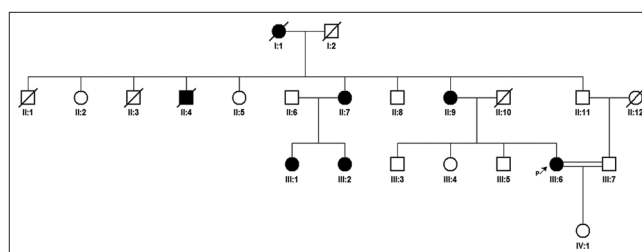

Figure 1: Pedigree of one family with p.G253E mutation

In the remained studied families, two new unreported nonpathogenic variants [Figure 6] were found in intron 8 of *HNF1A*. Finally, in two families, neither mutation nor common variant were found.

In silico analysis

Sanger sequences results were analyzed using Mutation taster 2.0, Polyphen-2, FATHMM, SIFT, PON-P2, PROVIAN, and PANTHER software tools to predict the effects of the identified variants [Tables 2 and 3]. Protein modeling was accomplished using swissmodel.expasy.org online program, based on 1IC8 PDB structure of *HNF1A* [Figure 7a and b].

Discussion

So far, up to 450 different mutations in *HNF1A* gene have been reported to cause MODY3.^[12] For the first time, here, we report a mutation c.758G>A (p.G253E) in exon 4 of *HNF1A* in two unrelated kindreds from Iran. The mutation was first reported by Colclough *et al.* (2014, unpublished data).^[1]

We also looked at the molecular mechanisms through which the current mutation causes diabetes. G253 is within the DBD of the *HNF1A* protein. It is a small neutral amino acid which apparently plays important roles in establishing intermolecular hydrogen bounds in the protein.^[16] Indeed, G253 is situated in the POU domain of the protein, a highly conserved domain having homology with Pit-1 and Oct-1 POU domains. The side chain of glycine is a sole hydrogen atom, whereas glutamic acid has a double negative charge with a big side chain. G253>E substitution

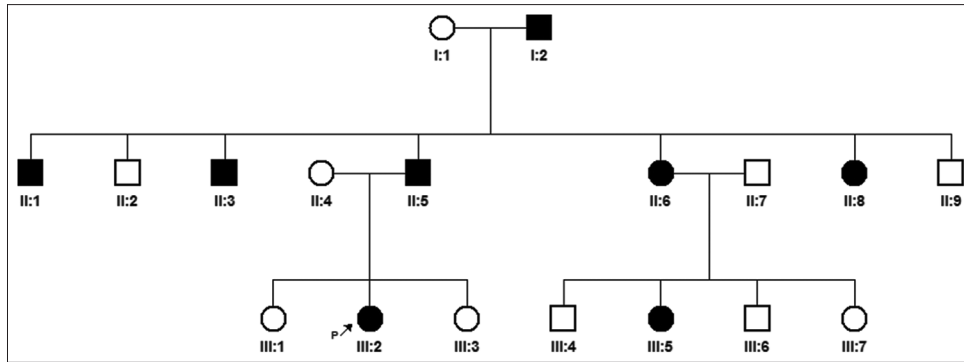

Figure 2: Pedigree of the second family with p.G253E mutation

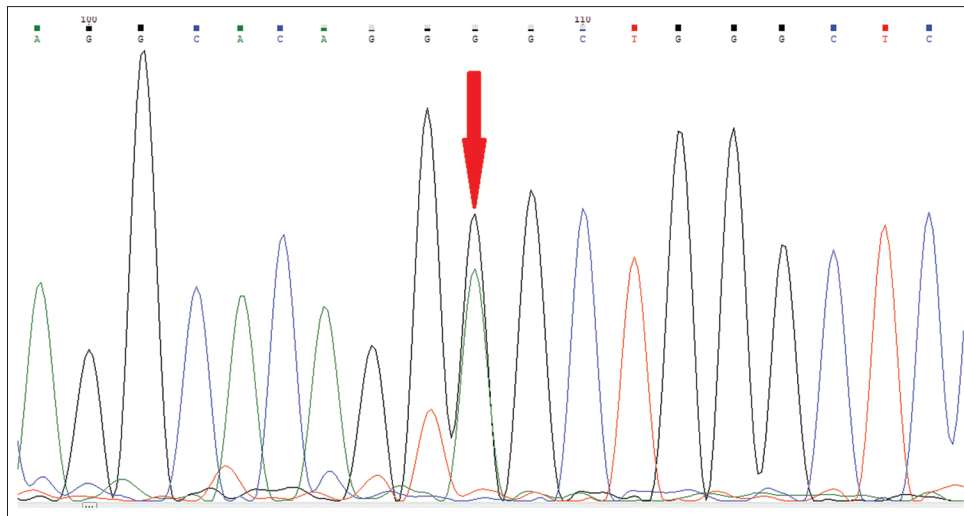

Figure 3: Heterozygous mutation c.758G > A (p.G253 > E) in the hepatocyte nuclear factor 1 alpha gene

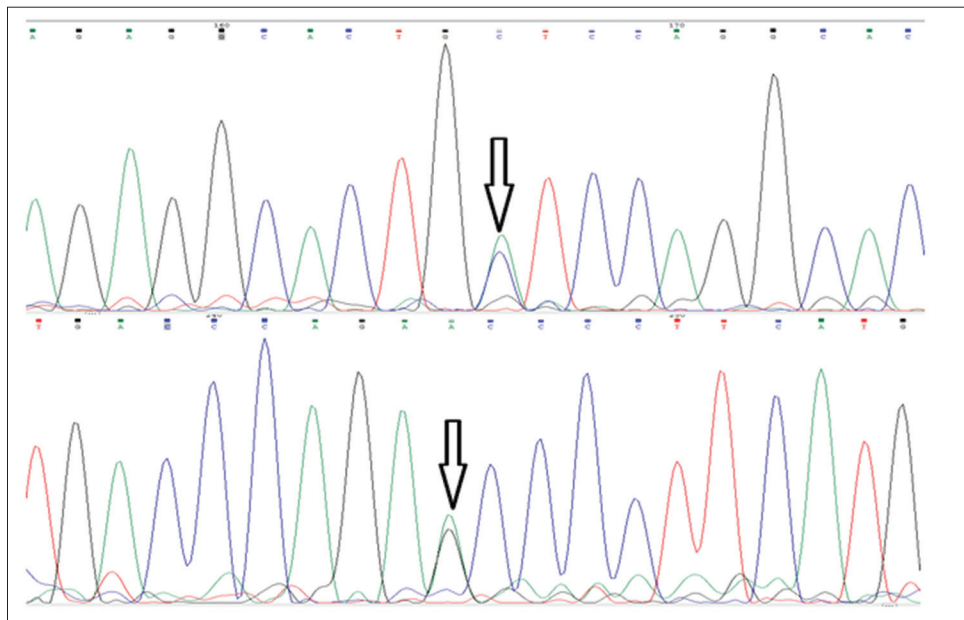

Figure 4: Common variant p.I27L (above) in exon 4 and common variant S487N (down) in exon 7 of hepatocyte nuclear factor 1 alpha

can lead to considerable changes in this substantial region of the protein. Based on Chi *et al.*'s work on the effects of

some mutations in the crystallized structure of the HNF1A protein, missense mutations in the DBD of HNF1A reduce

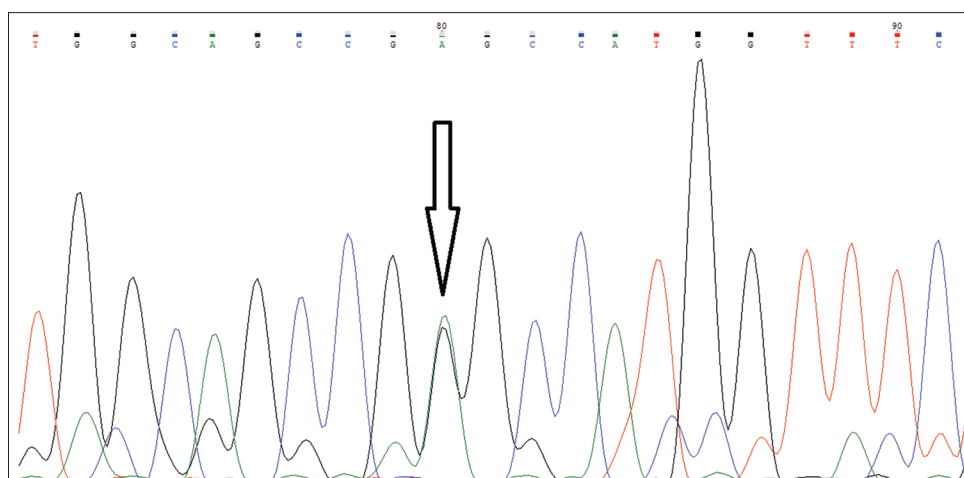

Figure 5: Rere polymorphism rs561269721 in nucleotides coding for Kozak sequence

Table 2: *In silico* analysis of variant pathogenicity

Variant/genomic location	Exon	Amino acid alteration	Software	Mutation Taster2.0	Polyphen-2	FATHMM	SIFT	Pon-p2	PANTHER
g.223	5'UTR	No	Prediction Score	Disease-Causing NA	-	-	-	-	-
g.305A>Cc.79A>C	1	p.I27L	Prediction Score	polymorphism NA	Probably Damaging 1.00	Damaging 1	Tolerable 0.331	Unknown 0.352	Probably Damaging PSEP: 797MY
g.15666G>Ac.758 G>A	4	p.G253E	Prediction Score	Disease Causing 98	Probably Damaging 1.00	Damaging -3.73	Damaging 0.00	Pathogenic 0.961	Probably Damaging PSEP: 842 MY
g.19082 G>Ac.1460 G>A	7	p.S487N	Prediction Score	polymorphism NA	benign 1.0	Damaging -4.39	Tolerable 0.14	Pathogenic 0.961	Probably Damaging PSEP: 455MY

PSEP: Preservation time for evaluated position, NA: Not available, MY: Million years

Table 3: Effect of the variant p.G>253E on protein deduced by PROVEAN

Software	p.I27L	p.G253E	p.S487N
PROVEAN Score	Neutral -0.917	Deleterious -5.472	Neutral -0.610

transcriptional activity of the gene.^[16] They investigated the effects of some mutations on the transcriptional activity of the gene and found that the V246D and N257W (which are situated in 5 prime and 3prime sides of the current mutation) reduced the transcriptional activity of *HNF1A* by 70%–75%, respectively.^[16] The rigidity of POU domains in the interface between POUH and POU S domains seems to be necessary for optimal transcription activity of the gene. One possible effect of the p. G>253E mutation is gain of flexibility for this region of the protein that can affect its optimal transcription activity.^[16] Missense mutations in TFs at DNA-binding or protein-binding sites are disease causing.^[17] Indeed, Kim *et al.* have worked on

the effects of missense mutations within POU domains of the *HNF1A* protein in Korean patients. They found the p.R263L mutation (exactly ten amino acid residues next to the p.G253) reduced the activation of downstream gene promoters, such as insulin and glucose transporter type 2 (*GLUT2*) promoters in NIH3T3 and MIN6N8 cells.^[18] Therefore, the p.G253E is important from two points of view. First, specific side chain-backbone hydrogen bond G253:Q176 and backbone-backbone G253: Q176 will be disrupted, and new hydrogen bonds are formed between glutamic acid big sidechain with other intermolecular amino acids in the *HNF1A* protein; the result is interruption of correct configuration of the protein or protein domains, and the second is the negative charge of glutamic acid that can interrupt interactions of DBD domain with DNA phosphate backbone. Therefore, these changes can lead to a reduction of optimal DNA-binding affinity of *HNF1A* with the promoter of downstream genes such as *GLUT2*, insulin, and pyruvate kinase, genes involved in glucose metabolism.^[19]

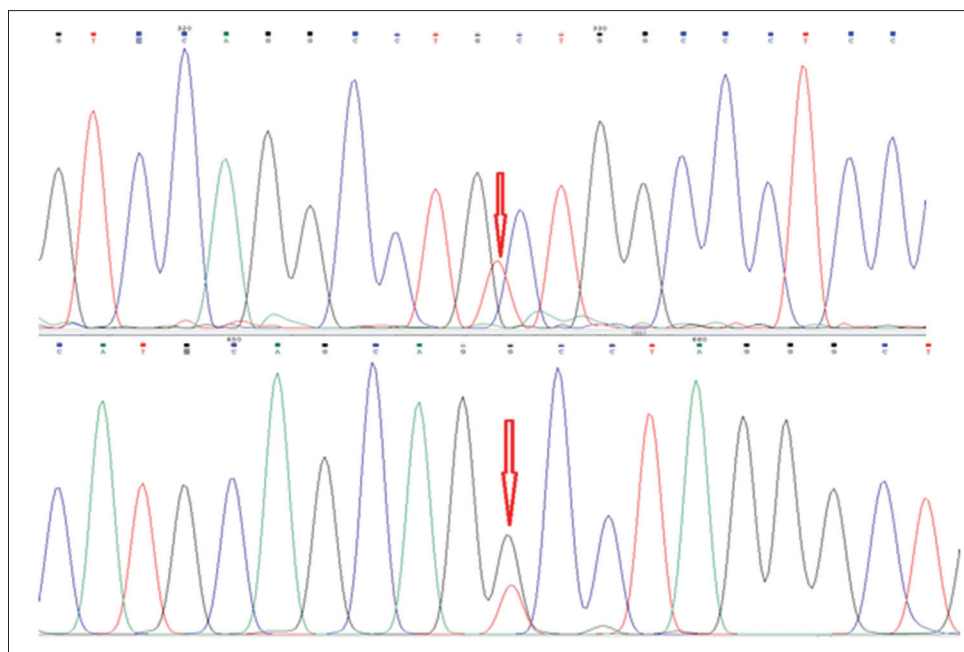

Figure 6: A novel variant g.20863-20864 insertionT in intron 8 (above) and novel variant g.21192G > T in intron 8 of hepatocyte nuclear factor 1 alpha (down)

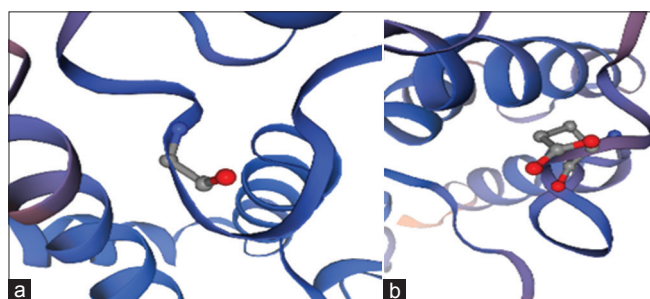

Figure 7: (a) Glycine at position 253 of the hepatocyte nuclear factor 1 alpha protein and (b) Glutamic acid is substituted for glycine at this position of the protein

The diabetes age of onset for the probands of two families carrying the same mutation was different; but, no main interfamilial differences were observed. The common phenotypic features include increased OGTT and high sensitivity to sulfonylureas. Clinical variation has been reported among MODY patients.^[20] The difference in age of onset between the two probands may be due to errors of diagnosis, or inheritance of different genes modifying the phenotype,^[21] and even environmental factors or different lifestyle.^[22]

Common variants p.I27L and p.S487N in *HNF1A* were reported as causing early-onset-inherited diabetes Type 2;^[23] also, these two common variants have been reported as MODY3 causing at heterozygous state.^[24] The findings of this research are in accordance of this two mentioned studies. The unknown issue is that any compound heterozygous state for these two variants can cause diabetes in early ages, or other factors such as Cis and Trans conditions for the two variants are important too. If the two variants in Cis conditions cause diabetes, one

of the possible interpretations may be haploinsufficiency; therefore, the diabetes is MODY. In Trans condition, the possible interpretation may be additive effect of the two variants, and early type 2 diabetes is the resulted condition. The other possibilities such as modifier loci, environmental factors, and other modifier variants in the gene should not be ignored.

The third finding of this study was rs561269721 (g.223G>A), a rare benign mentioned variant (MAF 0.012) in the Kozak sequence, that cosegregated with the condition in one of the studied families (LOD score = 3.01/ easy linkage software). The pathogenicity of this variant is in query because its global MAF is very low; the effect prediction for the variant was disease causing and the position of the variant is a critical position (-4 nucleotide) that may affect ribosomal binding activity or affinity.

Finally, two novel polymorphisms were detected in intron 8 of the gene. These two variants were predicted as nonpathogenic in *in silico* analyses, and they have no effect on splice sites or exon-intron junctions.

Conclusion

The role of *HNF1A* variants in development of diabetes has been somewhat known. Few studies have been performed on MODY and its subtypes in Iranian population. The etiology of MODY in our studied families was elucidated in 20% of the families, related to a missense mutation in *HNF1A*. Indeed, in this research, at least 70%–80% of early-onset diabetes depended on mutation or common variants in *HNF1A*. Whether or not, These common variants in the gene are considered as liability factors for T2DM or as MODY causing mutations, it is noteworthy

that compound heterozygous conditions of common variants in *HNF1A* can cause early-onset diabetes, and check of the population for this variants is necessary for the best management of this types of diabetes. The estimations of the current study may highlight the role of *HNF1A* in diabetic population of Iran. Certainly, to estimate the frequency of *HNF1A* MODY3 causing variants in Iranian population, more investigations are warranted. The project is in progress with consideration of the remaining families for the next generation sequencing.

Declaration of patient consent

The authors certify that they have obtained all appropriate patient consent forms. In the form, the patient has given her consent for her images and other clinical information to be reported in the journal. The patient understand that name and initials will not be published and due efforts will be made to conceal identity, but anonymity cannot be guaranteed.

Acknowledgments

We sincerely thank to all patients, and their families. This work is a partial result of M.Sc thesis performed by A.M. The study was supported by Isfahan University of Medical Sciences (grant no. 395116 and research study grant no: 295224), and the Shahrekord University of Medical Sciences (grant no. 2596).

Financial support and sponsorship

Nil.

Conflicts of interest

There are no conflicts of interest.

References

- Colclough K, Bellanne-Chantelot C, Saint-Martin C, Flanagan SE, Ellard S. Mutations in the genes encoding the transcription factors hepatocyte nuclear factor 1 alpha and 4 alpha in maturity-onset diabetes of the young and hyperinsulinemic hypoglycemia. *Hum Mutat* 2013;34:669-85.
- Vaxillaire M, Froguel P. Maturity-onset Diabetes of the Young: From Genetics to Translational Biology and Personalized Medicine. *Diabetes Associated with Single Gene Defects and Chromosomal Abnormalities*. Vol. 25. Basel: Karger Publishers; 2017. p. 26-48.
- Billings LK, Jablonski KA, Warner AS, Cheng YC, McAteer JB, Tipton L, *et al.* Variation in maturity-onset diabetes of the young genes influence response to interventions for diabetes prevention. *J Clin Endocrinol Metab* 2017;102:2678-89.
- Patel KA, Kettunen J, Laakso M, Stančáková A, Laver TW, Colclough K, *et al.* Heterozygous RFX6 protein truncating variants are associated with MODY with reduced penetrance. *Nat Commun* 2017;8:888.
- Fanjans SS, Bell GI. (2011). History, genetics, pathophysiology, and clinical decision making. *Diabetes Care*. Aug; 34 (8): 1878-1884. DOI.org/10.2337/dc11-0035.
- Shields BM, Hicks S, Shepherd MH, Colclough K, Hattersley AT, Ellard S. Maturity-onset diabetes of the young (MODY): How many cases are we missing? *Diabetologia* 2010;53:2504-8.
- Firdous P, Nissar K, Ali S, Ganai BA, Shabir U, Hassan T, *et al.* Genetic testing of maturity-onset diabetes of the young current status and future perspectives. *Front Endocrinol (Lausanne)* 2018;9:253.
- Acar S, Abacı A, Demir K, Özdemir TR, Özyılmaz B, Böber E. A novel *de novo* missense mutation in HNF4A resulting in sulfonylurea-responsive MODY. *J Clin Res Pediatr Endocrinol* 2017;9:15.
- Naylor RN, Montgomery JT, Lindauer K, Letourneau L, Bindal A, Sanyoura M, *et al.* Long Delay in Accurate Diagnosis of HNF1A-Mody in the US Monogenic Diabetes Registry. *Biology, Pathogenesis, and Clinical Dilemmas in Diabetes (posters)*: Endocrine Society; 2016.
- Bellanné-Chantelot C, Carette C, Riveline JP, Valéro R, Gautier JF, Larger E, *et al.* The type and the position of HNF1A mutation modulate age at diagnosis of diabetes in patients with maturity-onset diabetes of the young (MODY)-3. *Diabetes* 2008;57:503-8.
- Yamagata K, Oda N, Kaisaki PJ, Menzel S, Furuta H, Vaxillaire M, *et al.* Mutations in the hepatocyte nuclear factor-1alpha gene in maturity-onset diabetes of the young (MODY3). *Nature* 1996;384:455-8.
- Karaca E, Onay H, Cetinkalp S, Aykut A, Gökse D, Ozen S, *et al.* The spectrum of HNF1A gene mutations in patients with MODY 3 phenotype and identification of three novel germline mutations in Turkish population. *Diabetes Metab Syndr* 2017;11 Suppl 1:S491-6.
- Morita K, Saruwatari J, Tanaka T, Oniki K, Kajiwara A, Miyazaki H, *et al.* Common variants of HNF1A gene are associated with diabetic retinopathy and poor glycemic control in normal-weight Japanese subjects with type 2 diabetes mellitus. *J Diabetes Complications* 2017;31:483-8.
- Barzi SA, Ghaderian SM, Noormohammadi Z. A molecular case-control study of association of HNF1A gene polymorphisms (rs2259816 and rs7310409) with risk of coronary artery disease in Iranian patients. *Hum Antibodies* 2017;25:65-70.
- Tang J, Tang CY, Wang F, Guo Y, Tang HN, Zhou CL, *et al.* Genetic diagnosis and treatment of a Chinese Ketosis-prone MODY 3 family with depression. *Diabetol Metab Syndr* 2017;9:5.
- Sneha P, Thirumal Kumar D, Priya Doss CG, Siva R, Zayed H. Determining the role of missense mutations in the POU domain of HNF1A that reduce the DNA-binding affinity: A computational approach. *PLoS One* 2017;12:e0174953.
- Fajans SS, Bell GI. Phenotypic heterogeneity between different mutations of MODY subtypes and within MODY pedigrees. *Diabetologia* 2006;49:1106-8.
- Kammenga JE. The background puzzle: How identical mutations in the same gene lead to different disease symptoms. *FEBS J* 2017;284:3362-73.
- Schober E, Rami B, Grabert M, Thon A, Kapellen T, Reinehr T, *et al.* Phenotypical aspects of maturity-onset diabetes of the young (MODY diabetes) in comparison with type 2 diabetes mellitus (T2DM) in children and adolescents: Experience from a large multicentre database. *Diabet Med* 2009;26:466-73.
- Yang Y, Zhou TC, Liu YY, Li X, Wang WX, Irwin DM, *et al.* Identification of HNF4A mutation p.T130I and HNF1A mutations p.I27L and p.S487N in a Han Chinese family with early-onset maternally inherited type 2 diabetes. *J Diabetes Res* 2016;2016:3582616.
- Chi YI, Frantz JD, Oh BC, Hansen L, Dhe-Paganon S, Shoelson SE. Diabetes mutations delineate an atypical POU domain in HNF-1alpha. *Mol Cell* 2002;10:1129-37.
- Liang S, Tippens ND, Zhou Y, Mort M, Stenson PD, Cooper DN,

- et al.* IRegNet3D: Three-dimensional integrated regulatory network for the genomic analysis of coding and non-coding disease mutations. *Genome Biol* 2017;18:10.
23. Kim KA, Kang K, Chi YI, Chang I, Lee MK, Kim KW, *et al.* Identification and functional characterization of a novel mutation of hepatocyte nuclear factor-1alpha gene in a Korean family with MODY3. *Diabetologia* 2003;46:721-7.
24. Topaloğlu Ö, Evren B, Şahin İ. Monogenic diabetes case presented with symptomatic hyperglycemia and atypical mutation. *J Clin Res Pediatr Endocrinol* 2017;9:14.